

# USER MANUAL

**BarnColor-3/12G-SDI**  
**Barnfind Technologies AS**  
**Norway**



---

## TABLE OF CONTENTS

1. [Introduction](#)
2. [Safety Information \(general\)](#)
  - 2.1 [Safety Information \(laser safety\)](#)
3. [What's in the Box / Package Contents](#)
4. [Product Overview](#)
5. [Installation / Setup](#)
  - 5.1 [Brackets for mounting](#)
6. [How to Use](#)
  - 6.1 [As a pair](#)
  - 6.2 [Cascade multiple units](#)
  - 6.3 [Cascade multiple units, different models](#)
  - 6.4 [Add more signals to a "full" daisy-chain](#)
7. [Troubleshooting](#)
8. [FAQs](#)
9. [Maintenance & Care](#)
10. [Technical Specifications](#)
11. [Optional Accessories](#)
12. [Warranty & Support](#)

---

## 1. INTRODUCTION

Thank you for choosing Barnfind products!

Welcome to the **BarnColor-3/12G-SDI User Manual**. This guide is designed to help you quickly set up, operate, and maintain your product to ensure optimal, long-term performance.

## 2. SAFETY INFORMATION (general)

**⚠ Important:** Read all safety instructions before use.

- Protect from water and moisture exposure.
- Keep out of reach of children.
- Disconnect before cleaning.

### 2.1 SAFETY INFORMATION (laser safety)



- Never look directly into a laser beam.
- Avoid pointing lasers at reflective surfaces to prevent unintended reflections.
- Do not point a laser at people, animals, or vehicles.
- Keep unauthorized personnel out of laser operation areas.
- Use lasers only in controlled environments designed for their class.

---

## 3. WHAT'S IN THE BOX / PACKAGE CONTENTS

- 1(2)x **BarnColor-4x-3G/12G-SDI**
- 2x Interconnection bracket
- 4x Rack ear

---

## 4. PRODUCT OVERVIEW

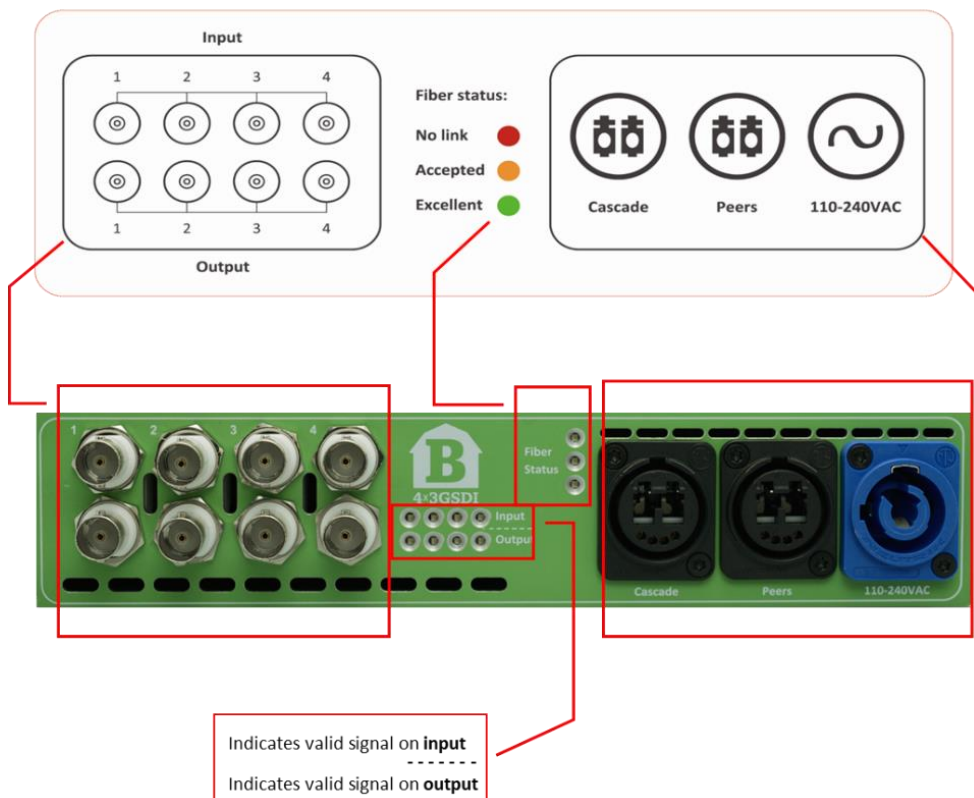

## 5. INSTALLATION / SETUP

1. Unpack all items.
2. If mounted in a 19" rack, attach the interconnection between units in front and rear, then the rack ears.
3. Power up the unit

### 5.1 Brackets for mounting

The units offer versatile mounting options for a 19" rack, allowing installation as single units or interconnected double units. Additionally, an optional bracket is available to securely mount and fasten a unit to an overhanging truss system.

You will need a Torx (T20) driver for this modification.



#### **Mount rack ears (Included):**

Remove the two corner screws (T20) from either the left or right side of the unit.

Use these same two screws to mount the "rack ear."



#### **Mount interconnection plate (Included):**

Remove the two corner screws (T20) from either the left or right side of the unit. Same side as the unit you want to inter-connect.

Use these same two screws to mount the "connection bracket".

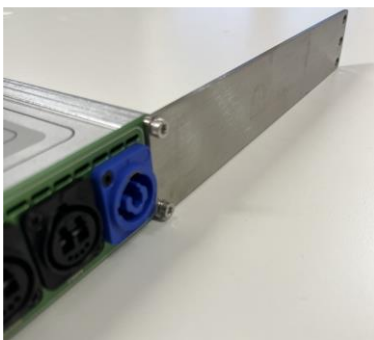

#### **Mount a blind plate for single unit in a 19" rack (Optional):**

Remove the two corner screws (T20) from either the left or right side of the unit.

Use these same two screws to mount the "blind plate."



**Mount a truss bracket (Optional):**

Remove the four corner screws (T20) from rear side of the unit. Pull the rear panel slightly sideways, enough to access the side rail.

Slide in the truss bracket all the way to the front panel.

Re-assemble the rear panel.

**6. HOW TO USE**

Designed to be a cost-effective and easy-to-deploy solution for transmitting multiple video signals both directions on a single fiber cable up to 10km distance. **BarnColor-3/12G-SDI** allows you to handle up to 32 x 3G-SDI signals (16 forward and 16 returns). Each **BarnColor-3/12G-SDI** device handles up to 8 signals (4 forward and 4 returns) and up to 4 different colors can be daisy-chained. This flexible system is easy to install, upscale and use.

**6.1 As a pair**

BarnColor can be coupled as a point to point link and will transmit/receive 4x SDI signals each way. This point to point connection can be done with any pair of color.

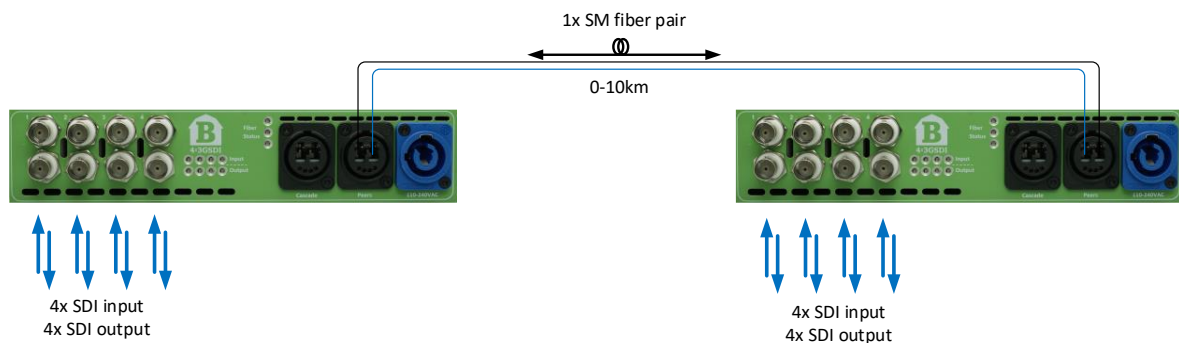

Barncolor products offer flexible connectivity, allowing them to be linked using two different connector types: the specialized Neutrik opticalCON DUO, or a standard duplex Single Mode fiber with LC-LC connectors.



*Neutrik opticalCON DUO*



*Standard LC-LC connectors*

## 6.2 Cascade multiple units

BarnColor devices can be daisy-chained and all signals for both directions will be transferred into the same fiber pair. Follow the diagram below for connections. You do not need to follow a specific color order when connecting. You will find the same diagram on top of the device.

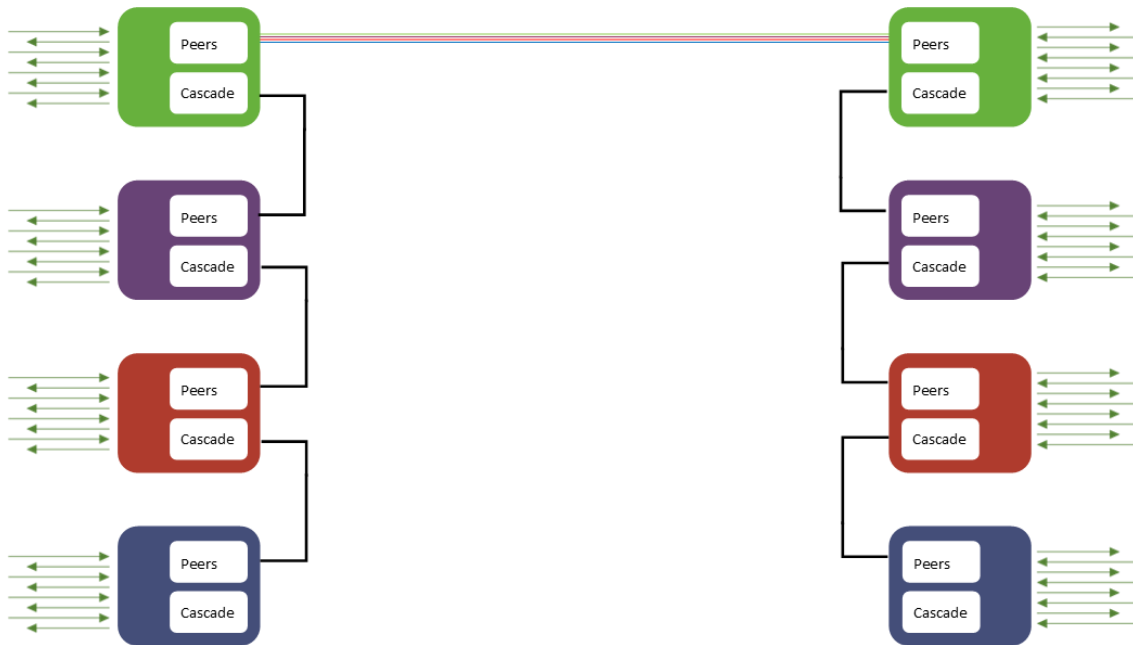

## 6.3 Cascade multiple units, different models



You can create a customized daisy-chain system by combining different models of BarnColors or using multiple units of the same model, **provided the colors used are distinct**. This flexibility allows you to tailor the system precisely to your required signal formats and quantities.

- You do not need to follow a specific color order when connecting
- Units within the daisy-chain can be placed across various locations, such as different rooms, floors, or even buildings, provided the total transmission distance does not exceed 10 km.

### 6.4 Add more signals to a “full” daisy-chain

BarnColor units utilize (CWDM) technology. This enables the transport of multiple signals over a single fiber core. Each Color unit converts signals to a unique wavelength, allowing signals from various Color units to be daisy-chained (as illustrated below).

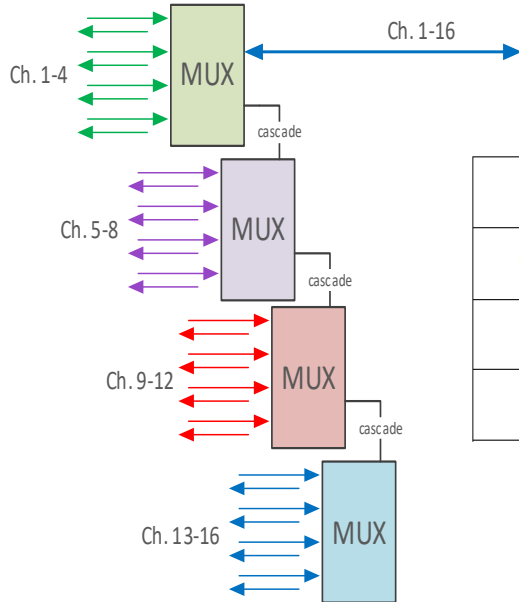

BarnColor CWDM Wavelength table

Green	1290	1310	1330	1350
Purple	1370	1390	1410	1430
Red	1470	1490	1510	1530
Blue	1550	1570	1590	1610

The BarnColor system intentionally reserves 1270nm and 1450nm wavelengths. This capacity can be utilized to integrate additional devices—including Barnfind products, network switches, or equipment from any third-party vendor—that operates at these specific wavelengths.

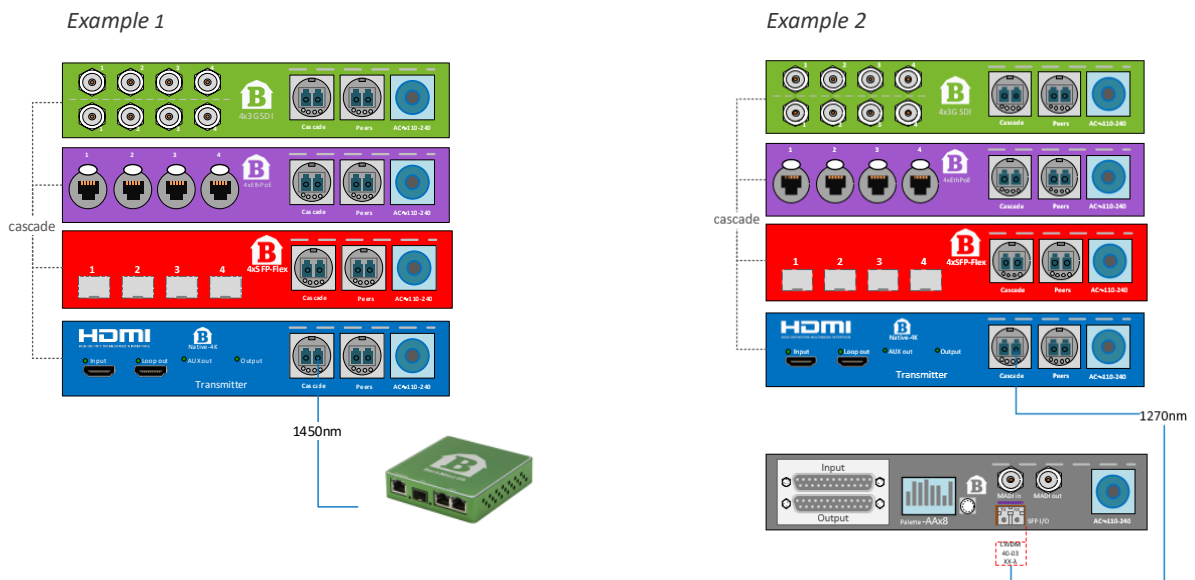

**⚠** When using BarnPalette OCS, 1270nm is occupied and cannot be used as described above.

## 7. TROUBLESHOOTING

Issue	Solution
No signal on output	<ul style="list-style-type: none"><li>• Check if [input LED] is green on the input side. This indicates the signal is a valid SDI, ASI or MADI.</li><li>• Check if [output LED] is green on the output side. This indicates a present signal on this BNC connector.</li><li>• Check if [Fiber Status LED] is green. This indicates an excellent fiber connection.</li></ul>
Fiber Status LED shows orange or red status	<ul style="list-style-type: none"><li>• Clean all fiber connectors and fiber ends. <a href="#">See chapter 9.0 about fiber cleaning.</a></li><li>• Fiber distance long/too long.</li><li>• Poor fiber or connector quality.</li></ul>

## 8. FREQUENTLY ASKED QUESTIONS

### **Q: How long distance can I transmit my signals?**

A: Up to 10 km (from beginning to end of the cascade) depending on the connector and fiber quality. Signals with lower bandwidth will reach longer than high-speed signals. You can expect a 3G-SDI signal to reach 40km+.

### **Q: Why can I not see signals at destination?**

A: Make sure all your connections are properly made. Then follow the steps in the “Troubleshooting” table.

### **Q: Can I mix & match different BarnColor models, e.g a green SDI and a blue Flex?**

A: Yes, this is the concept of BarnColor. You can mix any models in your daisy-chain as long as the color is different.

### **Q: With all my signals in 1x fiber pair, what can I do if I get a fiber failure?**

A: An OCS (Optical Changeover Switch) in both ends of your transmission will ensure a quick switch if there is a failure in your main fiber pair.

### **Q: How about redundant power?**

A: There is no redundant power supply in BarnColor or BarnPalette units but let us know if this is mandatory and we can add a PDU (Power Distribution Unit, with redundancy) to your design.

### **Q: What if I need more than 4 SDI signals?**

A: All BarnColor models are available in four (4) colors. You can daisy-chain a green SDI unit and a purple SDI unit in the same chain.

## 9. MAINTENANCE & CARE

It is critically important to clean fiber optic connector ends because even microscopic contamination can severely degrade or completely block the optical signal, leading to performance issues and potential permanent equipment damage.

Contamination on the connector end-face is consistently cited as the number one cause of fiber optic network failures across all environments.

### Always clean Before Mating!

- Use Only Fiber-Specific Cleaners: Never use alcohol, solvents, or cloths not specifically designed for fiber optics.
- Dry Cleaning: Use a fiber cleaning tool (e.g., a stick cleaner or cassette cleaner) designed for the specific ferrule size and connector type (LC)

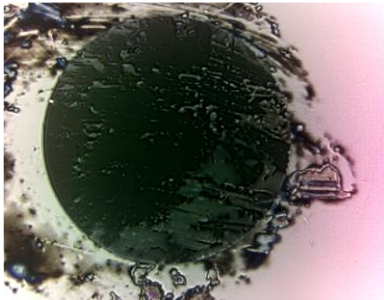

This microscope screenshot shows a typical contaminated fiber end, illustrating the residue left by a finger touch. This level of contamination will inevitably lead to a severely degraded signal strength, or potentially permanent damage to the fiber end.

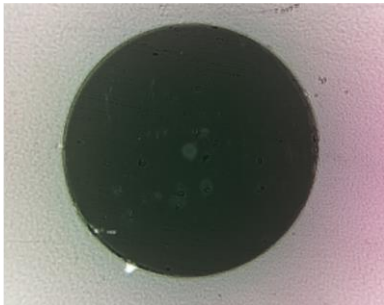

Same fiber end, after cleaning

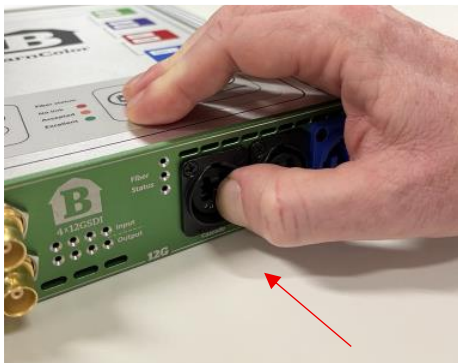

**⚠ Important:** The Neutrik opticalCON DUO connectors, used for Peer and Cascade connections, feature an internal sealing shutter to protect against contamination when the connector is disengaged.

Before inserting a cleaning tool, you must push the connector front inwards to open the sealing shutter.

## 10. TECHNICAL SPECIFICATIONS

Physical size:	223mm x 277mm x 44mm (8.8" x 10.9" x 1.7")
Weight:	1.4 kg
Power Supply:	AC 100V ~ 240V
Power Consumption:	15W
Power plug:	Neutrik powerCON or TRUE1

### **BNC-Ports (3G-SDI)**

- SMPTE 259M, 292M, 372M, 424M, DVB-ASI
- Multirate reclocking of outputs 270Mbps – 3Gbps

### **BNC-Ports (12G-SDI)**

- SMPTE 258M, 292M, 372M, 424M, DVB-ASI, SMPTE ST-2081, ST-2082
- Multirate reclocking of outputs 270Mbps – 12Gbps

### **Fiber port**

- Neutrik opticalCON DUO, also compatible with duplex Single Mode fiber LC-LC
  - SMPTE 297M
- 

## 11. Optional Accessories:

- BC-PowerCable-EU – 220VAC **Europe**/Schuko (Hybrid CEE 7/7 plug)
- BC-PowerCable-US – 110VAC **US** (NEMA 5-15 grounded (Type B))
- Blind plate
- Bracket for truss

## 12. WARRANTY & SUPPORT

This product comes with a 2-year limited warranty.

Contact support at [support@barnfind.no](mailto:support@barnfind.no) for claims and inquiries.